



Pure Sine Wave Inverter

User Manual



IP350-12/22/11/21
IP500-12/22/11/21
IP1000-12/22/11/21
IP1500-12/22/11/21
IP2000-22/42/21/41

CONTENTS

1. Important Safety Instructions	1
2. Introduction	3
3. Designations of models	4
4. Wiring	5
5. Functions	7
6. Protection	11
7. Troubleshooting	13
8. Maintenance	14
9. Disclaimer	15
10. Technical Specification	16

1. Important Safety Instructions

As an AC power supply equipment, the inverter's AC output is the same as the household power plug. The inverter's AC output should be treated with caution; otherwise, there will be a risk of electric shock! When using, please note the following:

Attentions:

- Connect the DC input according to the requirement strictly. The IPower inverter has a relatively wide DC input range. Still, too high or low DC input may cause problems and even destroy the inverter.
- A reverse polarity connection will blow the fuses in the inverter and damage the unit.
- Do not expose the inverter to a humid, salt spray, corrosion, greasy, flammable, explosive, or dust accumulation.
- Keep the inverter out of children's touch.
- It is recommended to connect the inverter input terminal to the battery. Calculate the minimum capacity of the battery (expressed in AH) in the following way: 5times of the rated power of the inverter/battery voltage. If for testing purposes, the user should select DC power supply current at least twice greater than that of the inverter rated input to keep normal inverter operation. Using a DC power supply for testing may cause damage to the inverter.
- When the inverter works continuously, its surface may become very hot; please ensure the air ventilation clearance around the inverter is more than 10cm. Keep away from the material or device which may suffer from high temperature when the inverter is working. Do not install the inverter in an airproof location and keep enough space around the inverter.
- Connect the protective grounding to the ground. The cross-section of the wire should not be less than 4mm².
- The wire connection between the battery and the inverter should be less than 3m, and the current density should be less than 3.5A/mm². At this time, the inverter is running at full load. If the wire length exceeds 3m, please reduce the current density.
- A fuse or breaker should be used between the battery and the inverter. The value of the fuse or breaker should be twice the inverter's rated input current.
- Do not connect the battery charger or similar devices to the inverter's input terminal.
- Do not put the inverter close to the flooded lead-acid battery because the terminals' sparkle may ignite the hydrogen released by the battery.

- It's an off-grid inverter. Do not connect the AC output terminals to the grid or electrical source. Otherwise, the inverter may be damaged.
- This inverter can only be used singly in parallel connections. The series connection will damage the inverters.
- Risk of electric shock. Don't touch the output port when the inverter is working. The output is forbidden to connect to other power sources or grids; otherwise, the inverter will be damaged. The inverter must be turned off when connecting the load.
- It is strictly forbidden to connect a transformer or a load with a surge power (VA) exceeding the overload power at the AC output port. Otherwise, the damage will be caused to the inverter.
- Please do not attempt to repair the fault inverter by yourself; otherwise, it may lead to a severe accident. Don't hesitate to get in touch with the manufacturer's engineer.
- IPower series is only suitable for civil applications, not for industrial applications.

2. Introduction

IPower series is a pure sine wave inverter that can convert 12/24/48VDC to 220/230VAC (or 110/120VAC). Industrial design has a wide operating temperature, high reliability, and high efficiency compared with civil design. Simple appearance and lightweight make it easy to install and operate. The wide input voltage range is ideal for solar system applications. This inverter is especially suitable for civil applications, such as household emergency lighting systems, vehicle-mounted systems, small field power supplies, etc.

Features:

- Safe design with input and output electrical isolation
- Adoption of advanced SPWM technology, pure sine wave output
- Optional output voltage 220/230VAC(or 110/120VAC), chosen by the DIP switch
- LED indicators for fault status and working status
- Lower No-load consumption
- Max. efficiency up to 95%(IP2000-22, IP2000-42)^①
- Input protection: Over voltage protection, low voltage protection
- Output protection: Overload protection, short circuit protection
- Over-temperature protection: Temperature-controlled Fan Ventilation; Inverter turns off automatically when overheating
- Operational USB output 5VDC/1A
- Operational RS485 communication port^②

① The efficiency is tested at rated input voltage,220V output with resistive load, 25°C Ambient temperature,1500W, and higher version

② 1000W and higher version support RS485 communication port optional.

3. Designations of models

IP 2000 - 4 2 (M U C)

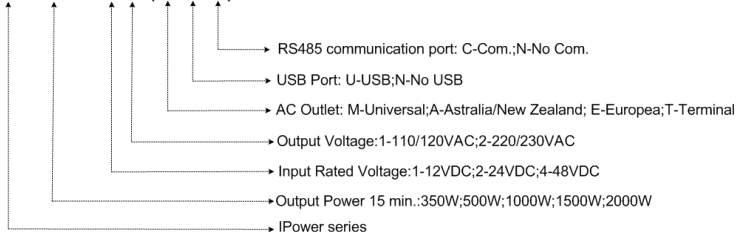

Output Voltage	Model	Input Rated Voltage	Output Power 15 min.
220/230VAC	IP350-12	12VDC	350W
	IP350-22	24VDC	350W
	IP500-12	12VDC	500W
	IP500-22	24VDC	500W
	IP1000-12	12VDC	1000W
	IP1000-22	24VDC	1000W
	IP1500-12	12VDC	1500W
	IP1500-22	24VDC	1500W
	IP2000-22	24VDC	2000W
110/120VAC	IP2000-42	48VDC	2000W
	IP350-11	12VDC	350W
	IP350-21	24VDC	350W
	IP500-11	12VDC	500W
	IP500-21	24VDC	500W
	IP1000-11	12VDC	1000W
	IP1000-21	24VDC	1000W
	IP1500-11	12VDC	1500W
	IP1500-21	24VDC	1500W
IP2000-21	24VDC	2000W	
IP2000-41	48VDC	2000W	

+ 220/230VAC output outlet: Universal, Australia/New Zealand, European, Terminal (IP1000 and above models).
 + 110/120VAC output outlet: Universal, Terminal (IP1000 and above models).
 + All the IPower models have an option for USB output.
 + All the IPower models have an option for RS485 communication except IP350 and IP500.

4. Wiring

(1) 12/24/48V system DC input

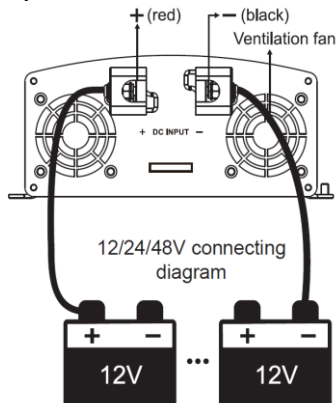

(2) 220/230V AC (or 110/120V) output

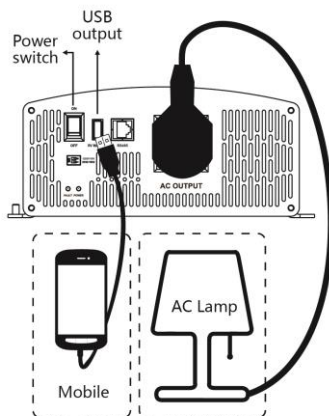

Operation Steps:

Step 1: Turn the power switch of the inverter to OFF.

Step 2: Disconnect the input breaker or the fuse between the inverter and battery. Connect the battery terminals ('+' with the red line and '-' with the black line). Do not connect the poles by contraries.

Step 3: Use the cable no less than 4mm² to connect the inverter's grounding terminal to the ground.

Step 4: Connect the plug of the AC load to the inverter AC outlet.

Step 5: Switch on the input breaker or the fuse between the inverter and battery; turn on the power switch to start the inverter. If the green indicator is ON, turn on the loads. Check the operation state of the inverter and loads.

Step 6: If there are different loads, the loads with higher startup current should be turned on first, such as television. After the loads work stably, turn on the loads with a lower startup current, such as an incandescent lamp.

Step 7: If the Fault indicator is red and the buzzer alarms when turning on the devices, please immediately switch off the loads and inverter.



Note: When using a USB port for charging, charge the power bank first and then use the power bank to charge mobile phones.

5. Functions

■ DC Input Panel

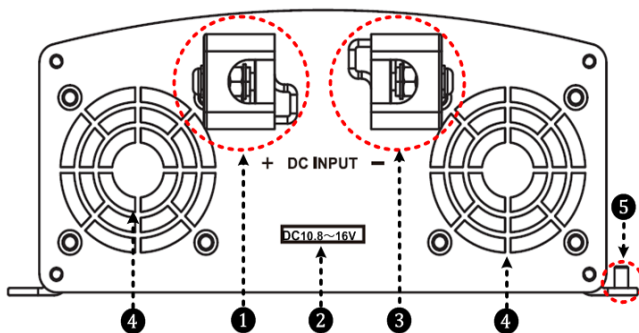

■ AC Output Panel

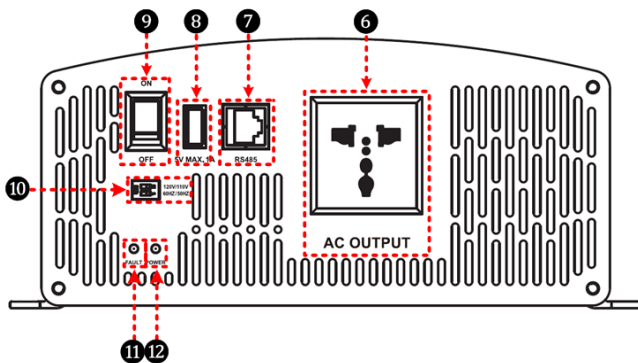

①	DC Input Terminal Positive	⑦	RS485 communication port ⁽⁴⁾
②	DC input voltage range ⁽¹⁾	⑧	USB output port (5VDC/1A)
③	DC Input Terminal Negative	⑨	AC output switch
④	Ventilation Fan ⁽²⁾	⑩	Mode switch ⁽⁵⁾
⑤	Grounding Terminal	⑪	Fault indicator(red) ⁽⁶⁾
⑥	AC Outlet ⁽³⁾	⑫	Working indicator(green) ⁽⁶⁾

(1) Input rated voltage

12V system input voltage range is 10.8~16V;

24V system input voltage range is 21.6–32V;

48V system input voltage range is 43.2–60V。

(2) Fan Ventilation

When the heat sink temperature is higher than 50°C or the internal temperature is higher than 50°C, the fan will turn on automatically.

When the heat sink temperature is lower than 40°C and the internal temperature is lower than 40°C, the fan will turn off automatically.

(3) AC Outlet (optional)

Universal

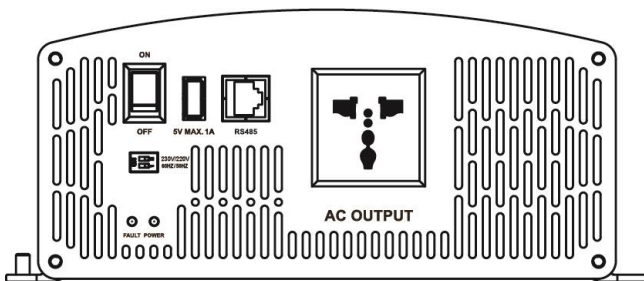

Australia/New Zealand

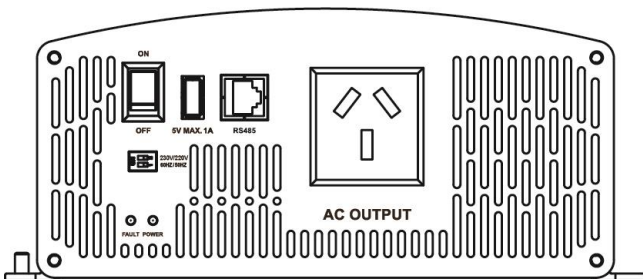

European

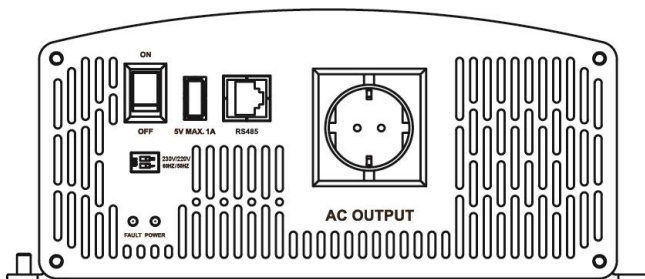

Terminal(IP1000 and above models)

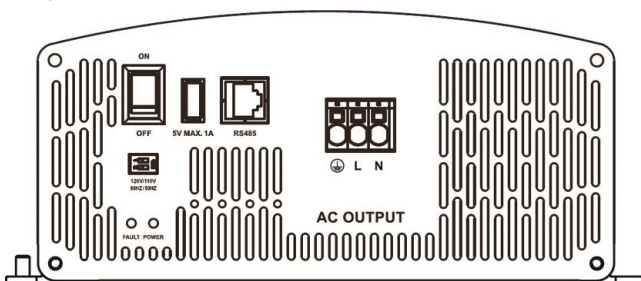

(4) RS485 communication port(IP1000 and above models optional)

The RJ45 interface pin definition:

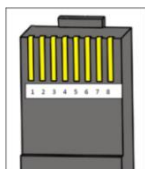

Pins	Define
1/2	5VDC
3/4	RS485-B
5/6	RS485-A
7/8	GND

(5) Mode Switch

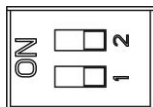

230V/220V
60HZ/50HZ

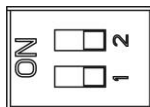

120V/110V
60HZ/50HZ

- When switch No.1 is on the ON side, the output frequency is 60Hz. Otherwise, it is 50Hz.
- When switch No.2 is on the ON side, the output voltage is 230VAC (120VAC).

Otherwise, it is 220VAC (110VAC).



NOTE: Turn off the inverter to reset the output frequency or voltage. Then, restart the inverter when the setting is complete.



WARNING: DO NOT turn ON/OFF the mode switch when the inverter is working.

(6) LED indicator and Buzzer

Working indicator	Fault indicator	Buzzer	Status
Green On Solid	Red OFF	No Sounding	Output is normal
Green Slowly Flashing (1/4Hz)	Red OFF	Sounding	Input under-voltage
Green Fast Flashing (1Hz)	Red OFF	Sounding	Input overvoltage
Green On Solid	Red ON Solid	Sounding	Over-temperature
Green OFF	Red Fast Flashing (1Hz)	Sounding	Load short circuit
Green On Solid	Red Slowly Flashing (1/4Hz)	Sounding	Overload
Green OFF	Red OFF	Sounding	Output voltage abnormal

6. Protection

Protection and recover	Condition			Phenomenon	
	Parameter	IPower-1*	IPower-2*		IPower-4*
Overvoltage protection and recover	Input Voltage U_i	$U_i > 16V$	$U_i > 32V$	$U_i > 64V$	Output is OFF Green indicator fast flashing Buzzer sounds
		$U_i \leq 14.5V$	$U_i \leq 29V$	$U_i \leq 58V$	Green indicator on solid The output is on
Low voltage protection and recover	Input Voltage U_i	$U_i < 10.8V$	$U_i < 21.6V$	$U_i < 43.2V$	Output is OFF Green indicator slowly flashing Buzzer sounds
		$U_i \geq 12.5V$	$U_i \geq 25V$	$U_i \geq 50V$	Green indicator on solid The output is on
Over-temperature protection and recover	Tem. (T)	Heat sink $T > 80^\circ C$ (IP1000 $T > 75^\circ C$) or Internal $T > 60^\circ C$			Inverter turns OFF
		Heat sink $T \leq 70^\circ C$ (IP1000 $T \leq 65^\circ C$) and Internal $T \leq 50^\circ C$			Inverter turns ON
Overload protection and recover	S: Output power P _e : Rated power	$S = 1.2P_e$ ^①			The output is OFF after 15min Red indicator slowly flashing Buzzer sounds
		$S = 1.5P_e$ ^①			The output is OFF after 30s ^② Red indicator slowly flashing Buzzer sounds

		$S=1.8P_e$ ①	The output is OFF after 10s Red indicator slowly flashing Buzzer sounds
		$S>2P_e$ (Rated input voltage)①	The output is OFF after 5s Red indicator slowly flashing Buzzer sounds
Load short circuit protection②			The output is OFF immediately Red indicator fast flashing Buzzer sounds

- ① When output overload protection or load short circuit protection is activated, the AC output would auto-recovery three times (the first time delays for 5s, the second time delays for 10s, and the third time delays for 15s). After three attempts, the AC output would not auto-recover. It can only be recovered after restarting the inverter. (When $S=1.2P_e$, the models don't have the auto-recovery function, except IP350 and IP500.)
- ② IP350 and IP500 stop output after 1 minute.

7. Troubleshooting

Faults	Possible reasons	Troubleshooting
Green indicator slowly flashing Buzzer sounds	DC input under-voltage	Measure the DC input voltage if the voltage is lower than 10.8/21.6/43.2V. Adjust the input voltage to restore normally.
Green indicator fast flashing Buzzer sounds	DC input overvoltage	Measure the DC input voltage if the voltage is higher than 16/32/64V. Adjust the input voltage to restore normally.
Red indicator slowly flashing Buzzer sounds	Overload	<ul style="list-style-type: none"> • Reduce the number of AC loads. • Restart the inverter.
Red indicator fast flashing Buzzer sounds	Short circuit	<ul style="list-style-type: none"> • Check carefully loads connection, clear the fault. • Restart the inverter.
Green and red indicators on solid Buzzer sounds	Over-temperature	<p>When the heat sink temperature exceeds 80°C, or the internal temperature exceeds 60°C, the inverter automatically turns off the output.</p> <p>The inverter resumes work when the heat sink temperature goes below 70°C, or the internal temperature goes below 50°C.</p>

8. Maintenance

The following inspections and maintenance tasks are recommended at least two times per year for good performance.

- Make sure no block on airflow around the inverter. Clear up any dirt and fragments on the heat sink.
- Check all the naked wires to ensure insulation is not damaged by sun exposure, frictional wear, dryness, insects or rats, etc.
- Verify the indicator display is consistent with the actual operation.
- Confirm that terminals have no corrosion, insulation damage, high temperature, burnt/discolored sign, and tighten terminal screws to the suggested torque.
- Clear up dirt, nesting insects, and corrosion in time.
- Check and confirm that the lightning arrester is in good condition. Replace a new one in time to avoid damaging the inverter and other equipment.



WARNING: Risk of electric shock!

Confirm all the power is turned off and all the capacitor's energy has been discharged before performing the above operations.

9. Disclaimer

The warranty does not apply to the following conditions:

- Damage is caused by improper use or an inappropriate environment (humid, salt spray, corrosion, greasy, flammable, explosive, dust accumulative, or other severe environments).
- The actual current/voltage/power exceeds the limit value of the inverter.
- Damage caused by working temperature exceeds the rated range.
- Arc, fire, explosion, and other accidents are caused by failure to follow the inverter stickers or manual instructions.
- Disassemble and repair the inverter without authorization.
- Damage caused by force majeure.
- Damage occurred during transportation or handling.
- Before using precise instruments, such as a medical instruments, end-users must read the manual carefully and ensure the inverter's output power/output voltage is suitable. We are not responsible for the instrument damage caused by improper use.

10. Technical Specification

Item	IP350-11	IP350-12	IP350-21	IP350-22
Rated Input Voltage	12VDC		24VDC	24VDC
Input Voltage Range	10.8~16VDC		21.6~32VDC	21.6~32VDC
Input surge voltage	<32VDC		<44VDC	<44VDC
Output Voltage	110VAC (±5%) 120VAC (-10%~+5%)	220VAC (±5%) 230VAC (-7%~+5%)	110VAC (±5%) 120VAC (-10%~+5%)	220VAC (±5%) 230VAC (-7%~+5%)
Output Frequency	50/60±0.1Hz			
Output Continuous Power	280W			
Output Power 15 min.	350W			
Surge power	750W			
Power factor	0.2-1(VA lower than output continuous power)			
Output Wave	Pure sine wave			
Distortion THD	THD≤5% ^①	THD≤3% ^①	THD≤5% ^①	THD≤3% ^①
Max. Efficiency	90%	91%	91%	92%
No-load current	<0.7A		<0.5A	
USB Output Port ^②	5VDC/Max.1A			
Binding post	Φ6mm			
Dimension	214×105.5×57.7mm			
Mounting size	185.5×76.7mm			
Mounting hole size	Φ4.2mm			
Net weight	1.0kg			

① Test condition: Rated Input Voltage, Output Continuous Power, Resistive load.

② Conventional products don't have this port, the port is optional.

Item	IP500-11	IP500-12	IP500-21	IP500-22
Rated Input Voltage	12VDC		24VDC	
Input Voltage Range	10.8~16VDC		21.6~32VDC	
Input surge voltage	<32VDC		<44VDC	
Output Voltage	110VAC (±5%) 120VAC (-10%~+5%)	220VAC (±5%) 230VAC (-10%~+5%)	110VAC (±5%) 120VAC (-10%~+5%)	220VAC (±5%) 230VAC (-10%~+5%)
Output Frequency	50/60±0.1Hz			
Output Continuous Power	400W			
Output Power 15 min.	500W			

Surge power	1000W			
Power factor	0.2-1(VA lower than output continuous power)			
Output Wave	Pure sine wave			
Distortion THD	THD \leq 5% ^①	THD \leq 3% ^①	THD \leq 5% ^①	THD \leq 3% ^①
Max. Efficiency	91%	92%	91%	92%
No-load current	<0.9A		<0.5A	
USB Output Port ^②	5VDC/Max.1A			
Binding post	Φ 6mm			
Dimension	232.2x132x74.5mm			
Mounting size	205x102mm			
Mounting hole size	Φ 5.2mm			
Net weight	1.7kg			

① Test condition: Rated Input Voltage, Output Continuous Power, Resistive load.

② Conventional products don't have this port, the port is optional.

Item	IP1000-11	IP1000-12	IP1000-21	IP1000-22
Rated Input Voltage	12VDC		24VDC	
Input Voltage Range	10.8~16VDC		21.6~32VDC	
Input Surge Voltage	<20VDC		<44VDC	<40VDC
Output Voltage	110VAC/120VA C (\pm 3%)	220VAC/230VA C (\pm 5%)	110VAC/120VA C (\pm 3%)	220VAC/230VA C (\pm 5%)
Output Frequency	50/60 \pm 0.1Hz			
Output Continuous Power	800W			
Output Power 15 min.	1000W			
Surge power	1600W			
Power factor	0.2-1(VA lower than output continuous power)			
Output Wave	Pure sine wave			
Distortion THD	THD \leq 5% ^①	THD \leq 3% ^①	THD \leq 5% ^①	THD \leq 3% ^①
Max. Efficiency	92.5%	94.5%	92.5%	94.5%
No-load Current	<0.8A		<0.5A	
USB Output Port ^②	5VDC/Max.1A			
RS485 Com. Port ^②	5VDC/200mA			
Binding Post	Φ 6mm			
Dimension	298.3x231.5x98.5mm		284.7x231.5x98.5mm	
Mounting size	183x220mm		163x219.5mm	
Mounting hole size	Φ 5.5mm			
Net Weight	3.9kg		3.6kg	

① Test condition: Rated Input Voltage, Output Continuous Power, Resistive load.

② Conventional products don't have this port, the port is optional.

Item	IP1500-11	IP1500-12	IP1500-21	IP1500-22
Rated Input Voltage	12VDC		24VDC	
Input Voltage Range	10.8~16VDC		21.6~32VDC	
Input Surge Voltage	<20VDC		<40VDC	
Output Voltage	110VAC (±3%) 120VAC (-7%~+3%)	220VAC (±5%) 230VAC (-7%~+5%)	110VAC (±3%) 120VAC (-7%~+3%)	220VAC (±5%) 230VAC (-7%~+5%)
Output Frequency	50/60±0.1Hz			
Output Continuous Power	1200W			
Output Power 15 min.	1500W			
Surge power	2400W			
Power factor	0.2-1(VA lower than output continuous power)			
Output Wave	Pure sine wave			
Distortion THD	THD≤5% ^①	THD≤3% ^①	THD≤5% ^①	THD≤3% ^①
Max. Efficiency	93%		94%	
No-load Current	<1.0A		<0.6A	
USB Output Port ^②	5VDC/Max.1A			
RS485 Com. Port ^②	5VDC/200mA			
Binding Post	Φ6mm			
Dimension	326.12×231.5×98.5mm		284.7×231.5×98.5mm	
Mounting size	208×220mm		163×219.5mm	
Mounting hole size	Φ5.5mm			
Net Weight	4.6kg		3.9kg	

① Test condition: Rated Input Voltage, Output Continuous Power, Resistive load.

② Conventional products don't have this port, the port is optional.

Item	IP2000-21	IP2000-22	IP2000-41	IP2000-42
Rated Input Voltage	24VDC		48VDC	
Input Voltage Range	21.6~32VDC		43.2~60VDC	
Input Surge Voltage	<40VDC		<80VDC	
Output Voltage	110VAC (±5%) 120VAC (-10%~+5%)	220VAC (±5%) 230VAC (-10%~+5%)	110VAC (±5%) 120VAC (-10%~+5%)	220VAC (±5%) 230VAC (-10%~+5%)
Output Frequency	50/60±0.1Hz			
Output Continuous Power	1600W			
Output Power 15 min.	2000W			

surge Power	3200W			
Power factor	0.2-1 (VA lower than output continuous power)			
Output Wave	Pure sine wave			
Distortion THD	THD \leq 5% ^①	THD \leq 3% ^②	THD \leq 5% ^③	THD \leq 3% ^④
Max. Efficiency	94%	95%	94%	95%
No-load Current	< 0.6A		< 0.4A	
USB Output Port ^⑤	5VDC/Max. 1A			
RS485 Com. Port ^⑥	5VDC/200mA			
Binding Post	Φ 6mm			
Dimension	326.12x231.5x98.5mm			
Mounting size	208x219.5mm			
Mounting hole size	Φ 5.5mm			
Net Weight	4.6kg			

① Test condition: Rated Input Voltage, Output Continuous Power, Resistive load.

② Conventional products don't have this port, the port is optional.

Environmental Parameters

Working Temperature	-20°C~ +45°C
Storage Temperature	-35°C~ +70°C
Humidity	< 95% (N.C.)
Enclosure	IP20
Altitude	< 5000 m (If the altitude exceeds 1000 meters, the rated power will be reduced according to IEC62040.)

Others

Dielectric Strength	Between DC input terminals and metal case: Test voltage AC500V, 1 minute Between AC output terminals and metal case: Test voltage AC1500V, 1 minute
---------------------	--

Any changes without prior notice! Version number: V2.4

HUIZHOU EPEVER TECHNOLOGY CO., LTD.

Tel: +86-752-3889706

E-mail: info@epever.com

Website: www.epever.com