



# ATZ3600

## Portable Power Station

### USER MANUAL

## Table of Contents

Important Safety Instructions .....	1
Disclaimers .....	5
1 General Information .....	6
1.1 Overview .....	6
1.2 Appearance .....	8
1.3 Ambient light .....	10
1.4 LCD .....	10
1.5 Switches .....	14
1.6 Naming rules .....	16
2 Use the Power Station .....	17
2.1 Outward power supply .....	17
2.2 Charge the power station .....	18
2.2.1 Grounding .....	18
2.2.2 Solar power charging .....	19
2.2.3 Car charging .....	19
2.2.4 AC charging .....	20
2.2.5 Solar plus AC simultaneous charging .....	20
2.3 EPS (Emergency Power Supply) .....	21
2.4 Connect to secondary battery pack (Optional) .....	22
2.4.1 Appearance of secondary battery pack .....	22
2.4.2 Installation of secondary battery pack .....	22
2.5 Application scenarios .....	24
2.6 Protections for the secondary battery pack .....	26
3 Remote Control of Power Station .....	27
3.1 Remote controller .....	27

3.2 APP remote control .....	29
3.2.1 Download the APP .....	29
3.2.2 Register and Log in the APP .....	30
3.2.3 Add the power station .....	32
3.2.4 View the power station .....	34
3.2.5 Edit the power station .....	36
3.2.6 Software update .....	36
4 Troubleshooting .....	40
5 Technical Specifications .....	43
5.1 Parameters for main battery pack .....	43
5.2 Parameters for secondary battery pack .....	47

## Important Safety Instructions

### Please keep this manual for future reference.

This manual contains the safety, installation, and operation instructions for the ATZ3600 series (ATZ3600EU/ATZ3600UK/ATZ3600AU/ATZ3600US) portable power station (hereinafter referred to as "power station").

Before using the power station, please read the user manual carefully to understand its operation and safety features.

#### **Proper installation:**

Install the power station as per the instructions provided in the user manual. Improper installation may result in power station failure or damage.

#### **Ventilation:**

Always use and store the power station in a well-ventilated place. Overheating may cause damage to the power station or fire hazard.

#### **Exclusion of water:**

Do not put the power station in contact water or in a wet environment for a long time, otherwise may cause short circuit and damage to the power station.

#### **Temperature:**

Do not use or store the power station in extremely hot or cold environments, otherwise may damage the battery and shorten its service life.

#### **Handling:**

Handle the power station with care. Avoid dropping or impacting it.

#### **Electrical safety:**

Do not attempt to disassemble, repair, or modify the power station. For any necessary maintenance, please contact our after-sales service personnel.

#### **Charging:**

Only the power station can be charged within the input voltage range specified by the product. Exceeding the input voltage range may cause damage.

#### **Storage:**

If the power station has been not used for a long time, store it in a cool, dry place, and charge it every three months to keep the battery in good conditions.

#### **Waste disposal:**

At the end of the service life of the power station, please dispose of it responsibly in accordance with local battery disposal regulations.

## 1. Safety precautions regarding risks of fire, electric shock, or personal injury

When using this product, always follow basic preventive measures, specifically as follows:

- Please read the instructions carefully before use.
- When using the product around children, conduct close supervision to reduce the risk of injury.
- Do not insert fingers or hands into the product.
- Using accessories not recommended or sold by our company may cause risks of fire, electric shock, or personal injury.
- To reduce the risk of damaging the power plug and power cord, unplug the plug rather than the power cord when disconnecting the power station.
- Do not use damaged or modified power station or equipment. Damaged or modified power station may exhibit unpredictable behavior, leading to risks of fire, explosion, or injury.
- Do not operate the power station with damaged wires, plugs, or output cables.
- Do not disassemble the power station. If you need maintenance or repair, please contact qualified maintenance personnel. Improper reassembly may cause risks of fire or electric shock.
- To reduce the risk of electric shock, unplug the power station from the socket before attempting any instructed repairs.
- Do not smoke or generate sparks or flames near the power station.
- When charging the built-in battery, work in a well-ventilated area and do not restrict ventilation in any way.
- Do not expose the power station to fire or high temperature. Exposure to fire or temperatures above 130°C (265°F) may cause explosion.
- Use the same parts for repair by qualified technicians, so as to ensure the safety of the product.

## 2. Safety precautions for operation and use

- Use and store the power station only in clean, dry environments. Avoid use and storage in dusty and humid environments.
- Inspect the power station before each use. Do not use if it is damaged or broken.
- If any rust, unusual odor, overheating, or other abnormalities are found in the power station, immediately stop use and contact the distributor or our after-sales service personnel.
- Ensure the power station is properly secured when being transported in a motor vehicle.
- Charge the power station only within an ambient temperature range of 0 to 40°C (39 to 104°F), and discharge within a temperature range of -20 to 40°C (-4 to 104°F).

- In the event of accidental dropping or vibration, immediately power off the power station.
- Do not use the power station if the power cord is damaged or broken.
- Keep away from children and pets. Do not allow children to use the power station.
- Do not use the power station in high-temperature areas or environments.
- If the liquid inside the power station comes into contact with your skin or clothing, rinse the affected area with tap water.
- The power station is not permitted to be used in rainy or high temperature environments.
- Do not place the power station on its side or upside down during use or storage.
- Do not use the accessories for any other purpose.
- Ensure the power station is powered off before connecting.
- Do not expose the power station to fire or high temperature. Exposure to fire or temperature above 130°C (265°F) may cause explosion.
- The solar charging time depends on weather conditions. Place the solar panels where it can be exposed to direct sunlight as much as possible.
- Do not quickly swing the power station at a large angle when the secondary battery pack is installed on the upper part of the power station. Otherwise, the secondary battery pack may fall.
- Do not place the power station on the floor or at a height less than 457mm (18 inches) from the floor during use in repair of facilities.
- The power station is a ground device equipped with casters and tie rods. Do not place the power station higher than 10cm (3.9 inches). Otherwise, the damaged or explosion may occur.



**WARNING**

Do not disassemble the power station without permission. If you need to repair the power station, please contact the local distributor or our after-sales service personnel as soon as possible.



**CAUTION**

The power station is suitable for various occasions such as recreational vehicles, tents, and off-grid cabins, etc. Please make sure to follow the safety guidelines when using it outdoors. It can also serve as an emergency indoor power supply, providing reliable electricity at the crucial moment.

### 3. Safety precautions for movement and storage

- Do not move the power station when it is being charged or in use.
- Do not dispose of the power station with household waste.
- Do not place the power station near a source of fire or heat, and avoid direct sunlight. Avoid direct sunlight
- Do not store the power station in a bathroom, or expose it to a rainy, or a damp environment.
- Do not disassemble the power station. If you need maintenance or repair, please contact qualified maintenance personnel. Improper reassembly may cause risks of fire or electric shock.
- Do not store the power station in high-temperature areas or environments.
- To ensure the performance and lifespan of the power station are not affected during storage, it is recommended to carry out a charge and discharge operation every six months. Firstly, fully discharge the power station until the power indication shows 0%. Then, charge it to 100% and subsequently discharge it to 60% for storage. If the required storage operations are not performed and product issues occur as a result, such device problems are excluded from the company's warranty services.

### 4. Safety precautions for user maintenance

- Before use or storage, please ensure that the power station is fully charged. If the LCD displays low battery level, please promptly connect it to a power supply, such as an AC power outlet or a solar panel.
- When this product is used outdoors for a long time, please pay attention to whether the fan grids on both sides are blocked by foreign matters. If there are foreign matters, clean them up in time.

### 5. Safety precautions for battery use

- Re-placement of a battery with an incorrect type that can defeat a safeguard (for example, in the case of some lithium battery types);
- Disposal of a battery into fire or a hot oven, or mechanically crushing or cutting of a battery, that can result in an explosion;
- Leaving a battery in an extremely high temperature surrounding environment that can result in an explosion or the leakage of flammable liquid or gas;
- A battery subjected to extremely low air pressure that may result in an explosion or the leakage of flammable liquid or gas.

## Disclaimers

The company does not assume any responsibility for damage caused by the following circumstances:

- Damage caused by improper use or use in improper working environments (It is strictly prohibited to install the power station in severe environments that are humid, high salt spray, corrosive, greasy, flammable, explosive, or excessive in accumulation of dust).
- Damage caused by current, voltage, or power exceeding the specified limits of the power station.
- Damage caused by the working environment temperature exceeding the limited working temperature range.
- Accidents such as electrical arcs, fires, or explosions caused by failure to follow the power station markings or instructions in the manual.
- Unauthorized disassembly or repair of the power station.
- Damage caused by lightning strikes, heavy rain, floods, utility power failures or heavy force.
- Damage occurred during transportation or loading/unloading of the power station.



# 1 General Information

## 1.1 Overview

ATZ3600 is a 3,600W portable power station that integrates a variety of AC and DC output ports, including two 12VDC/10A cigarette lighter sockets, four USB-A ports (sharing a 5VDC/3A power supply for every two ports), two USB-C ports (sharing a 5VDC/3A power supply), two 100W USB-C PD ports, and four (ATZ3600EU/UK/AU) or six (ATZ3600US) AC output sockets (maximum output power of 3600W) to meet the power supply needs of different AC and DC devices.

It supports four charging modes: solar charging, car charging (via the car cigarette lighter socket), AC charging, and solar plus AC charging, allowing users to charge the power station in different scenarios (advocate for the prioritization of green energy for charging).

The power station comes with a remote control, allowing users to remotely power off and control various switch buttons, such as powering on or off AC and DC outputs, Bluetooth, LCD screen display, and ambient light brightness. Additionally, it is equipped with a built-in Bluetooth module, enabling users to remotely monitor the operation status of the power station and adjust relevant parameters through the phone APP.

The device is equipped with a large-capacity lithium iron phosphate battery and supports the addition of a secondary battery pack, which is suitable for use in various occasions such as self-driving camping, aerial photography, outdoor work, home power backup and other applications. It can also serve as an emergency indoor power supply, providing reliable power in critical moments.

## Features

- Multiple AC and DC output ports
- Four/Six AC output sockets with AC rated output power of 3600W, peak output power up to 5,400W
- Two 100W USB-C PD ports
- Two USB-C ports (sharing a 5VDC/3A power supply)
- Four USB-A ports (sharing a 5VDC/3A power supply for every two USB-A ports)
- Two 12VDC/10A cigarette lighter sockets
- Four ambient light modes can be switched at will
- Energy storage lithium iron phosphate battery and intelligent BMS management, durable in use
- Be compatible with solar charging, car charging, generator charging and utility charging, to meet all kinds of charging requirements
- Super fast charging, fastest charging up to 80% in just one hour

- Optional 2,048Wh secondary battery pack available
- No need for wiring between the secondary battery pack and the main unit, easy installation and disassembly
- Equipped with high-strength aluminum alloy telescopic handle and heavy-duty casters for easy mobility
- Equipped with a wireless remote control for output control and function buttons ON/OFF, and remote shutdown the device
- Built-in Bluetooth module for device monitoring and firmware updating via APP
- Energy saving mode and mute charging mode are optional
- It can supply power to 99% of common electrical equipment, suitable for self-driving camping, aerial photography, outdoor work, home power backup and other applications

## 1.2 Appearance

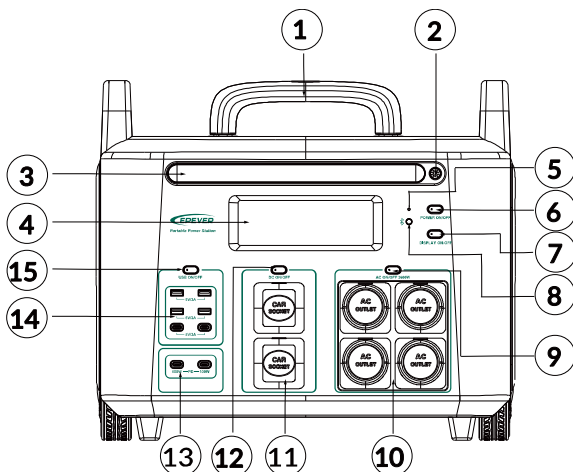

ATZ3600EU

ATZ3600UK

ATZ3600AU

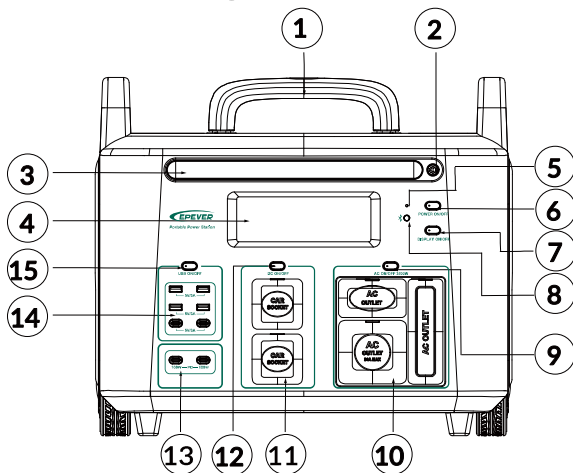

ATZ3600US

1	Telescopic handle	9	AC output switch
2	Ambient light switch	10	AC output socket *4 (ATZ3600EU/UK/AU) AC output socket *6 (ATZ3600US)
3	Ambient light	11	Car cigarette lighter socket *2 (12VDC/10A)

4	LCD	12	DC switch
5	Reset hole	13	USB-C PD port * 2 (100W PD)
6	Power switch	14	USB-A port *4 (5VDC/3A) USB-C port * 2 (5VDC/3A)
7	LCD display switch	15	USB switch
8	Bluetooth switch		

For detailed information on the functions of switches and the reset hole, please refer to Section [1.5 Switches](#).

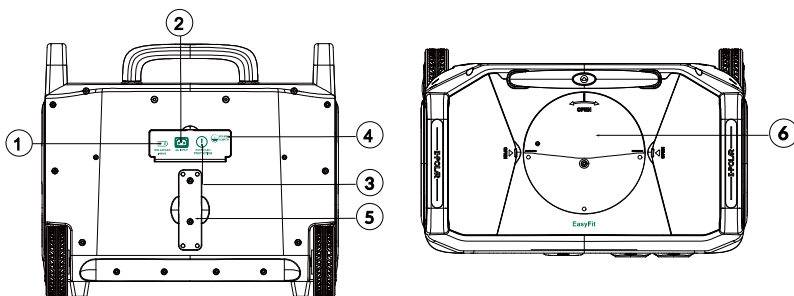

1	Solar panel/Car cigarette lighter socket charging terminal	4	Grounding sign
2	AC charging port	5	Remote control holder slot
3	Overload protector	6	Connection terminal for secondary battery pack

## 1.3 Ambient light

### Ambient lighting

The first click on the ambient light switch  powers on level 3 brightness; the second click powers on level 2 brightness; the third click powers on level 1 brightness (gradually decrease in brightness), and the fourth click powers off the ambient light.

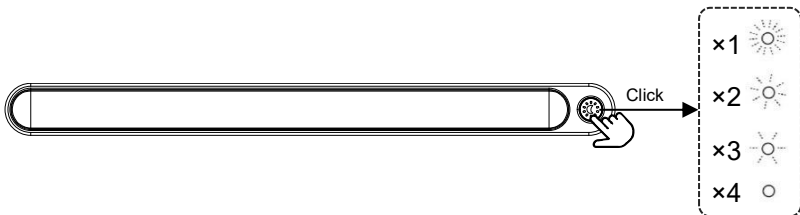

### SOS mode

The ambient light starts blinking at a certain frequency by long pressing on the ambient light switch  for 3 seconds to enter SOS mode.

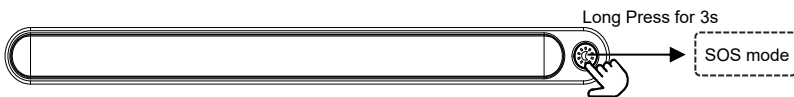

In the SOS mode, click  to power off the ambient light.





## 1.4 LCD

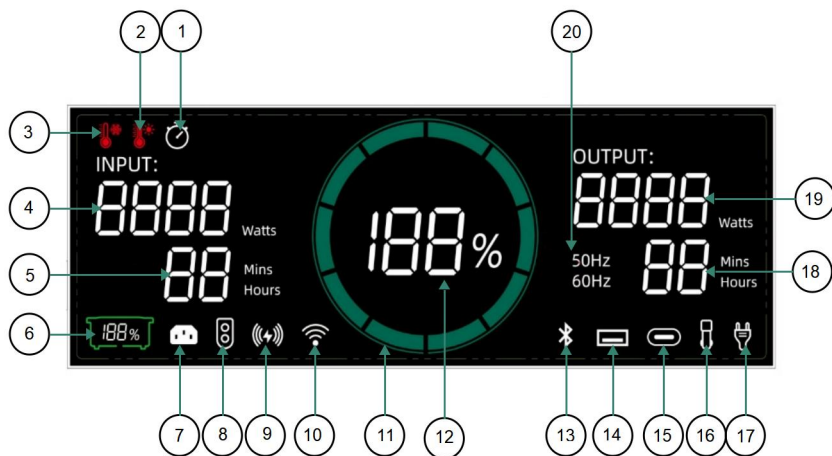



The LCD display provides real-time operating status of the power station, including remaining battery level, output power, remaining service time, charging time, etc. It also displays the status of USB-C, USB-A, cigarette lighter, AC input, Bluetooth, and battery pack.

The content displayed on the LCD can only be clearly viewed at the angle of 90° between the horizontal line of sight and LCD. If the angle exceeds 90°, the displayed content on the LCD will not be seen clearly.



No.	Name	Function description
1	Timing icon	Check if the APP has added a timing. The icon lights up when the timing set in the APP is greater than zero. The icon goes out when the timing is set to zero.
2	High temperature warning	When either the battery temperature (read from the BMS) of the main or secondary battery pack is higher than the high temperature threshold, the high temperature warning icon lights up. When the temperature decreases, the alarm is cleared and the icon goes out.
3	Low temperature warning	When either the battery temperature (read from the BMS) of the main or secondary battery pack is lower than the low temperature threshold, the low temperature warning icon lights up. When the temperature rises, the alarm is cleared and the icon goes out.
4	Input power	Display the sum of DC charging power and AC input power. The icon lights up with input power, and goes out without input power.









5	Remaining charging time	Display the remaining charging time. The icon lights up when the battery is charging and goes out when the battery is not charging. When the remaining charging time is less than 60 minutes, the actual minute is displayed. When the remaining charging time is more than 60 minutes, the hour value with decimal points is displayed. When the remaining charging time is greater than 99 hours, 99 hours is displayed.
6	Secondary battery pack icon, secondary battery pack remaining capacity	Determine if the main battery is connected to the secondary battery pack, and shows the remaining capacity of the secondary battery pack (read from the BMS of the secondary battery pack )  The icon lights up when connecting to the secondary battery pack, and goes out when the secondary battery pack is not connected.
7	AC input	Check the AC voltage. The icon lights up when the AC relay is connected, and goes out when the AC relay is disconnected.
8	DC input	The icon lights up with DC input voltage, and goes out without DC input voltage.
9	Wireless charging	Reserved
10	WiFi icon	Reserved
11	Battery level bar 	Display the corresponding SOC value (read from the BMS module).  The icon lights up when the device is powered on, and goes out when the device is powered off. Starting from R1 at the bottom-left, corresponding to battery level of 0 – 10%; R2 corresponds to battery level of 11 – 20%, until R10 corresponds to battery level of 91 – 100%.  <b>Note:</b> The battery level bar blinks when charging, and it will decrease as the remaining amount of electricity during discharging.
12	Remaining battery level	Display the percentage value of SOC (read from the BMS module). The icon lights up when the device is powered on, and goes out when the device is powered off.
13	Bluetooth icon	Check the output status of the Bluetooth button. The icon lights up after pressing  , and goes out after pressing  again.
14	USB-A, USB-C icon	Check the output status of the USB switch. The icon lights up after pressing  , and goes out after pressing  again.





15	USB-C PD icon	The icon lights up when there is a device connecting to the USB-C PD port, and goes out when the device is disconnected from the USB-C PD port.
16	Cigarette lighter icon	Check the output status of the DC switch. The icon lights up after pressing  , and goes out after pressing  again.
17	AC output	Check the status of the load output relay. The icon lights up after pressing  , and goes out after pressing  again. <b>Note:</b> When the icon  blinks, the device is in the overload lock state. You need to restart the device to resume normal work.
18	Remaining battery runtime	Display the remaining service time (battery life). The icon lights up when the battery is discharging and goes out when the battery is not discharging. If the remaining runtime is less than 60 minutes, the actual minute is displayed. When the remaining runtime is more than 60 minutes, the hour value with decimal points is displayed. If the remaining runtime is greater than 99 hours, 99 hours is displayed.
19	Output power	Display the sum of AC load power and DC output power. The icon lights up with output power, and goes out without output power. The DC output power is not displayed if it is less than 3W, and the AC output power is not displayed if it is less than 30W.
20	Frequency	Check if there is AC input or AC output. The icon displays the AC output frequency with AC input or output (50 Hz is displayed for a range of 40 – 55 Hz, and 60 Hz is displayed for a range of 56 – 70 Hz). The icon goes out without AC output and input.

The LCD for software updating, please refer to Subsection [3.2.6 Software update](#).



## 1.5 Switches

No.	Switch diagram	Switch name	Function description
1		Power switch	Output switch of battery BMS board. Long press for 3 seconds to power on, and long press for another 3 seconds to power off.
2		Display switch	Control the LCD backlight. Press to turn on and press again to turn off. <b>Note:</b> After the screen lights up, the initial 100 seconds are set at high brightness, and followed by 20 seconds at low brightness. It will automatically go out after 120 seconds of no operation, and will reset the timer with any operation.
3		USB switch	Control outputs of USB-A and USB-C ports. Press to turn on the USB output, and press again to clear the fault (if exists) or turn off the USB output.
4		DC switch	Control outputs of cigarette lighter sockets. Press to turn on the DC output, and press again to clear the fault (if exists) or turn off the DC output.
5		AC switch	Control AC output. Press to turn on the AC output, and press again to turn off the AC output.
6		Ambient light switch	The first click powers on 3-level brightness, and the second click powers on 2-level brightness; the third click powers on 1-level brightness, and the fourth click powers off the ambient light. Long press for 3 seconds to enter the SOS mode (the ambient light will blink at a certain frequency).
7		Bluetooth switch	Activate Bluetooth. Press to turn on, and press again to turn off. After turning on the Bluetooth switch, long press to unbind the device. <b>Note:</b> The wireless technology testing frequency and power is 2402MHz to 2480MHz @ 1.84 dBm.
8		Reset hole	Located above the Bluetooth switch. Press for soft reset of device information.

9	 AC ON/OFF +  DC ON/OFF	AC switch Plus DC switch	First press the AC switch to turn on the frequency display, and then press the AC switch and DC switch simultaneously to switch the AC output frequency.
10	 USB ON/OFF +  DC ON/OFF	USB switch Plus DC switch	Turn off the buzzer. Operating via the APP, refers to Subsection <a href="#">3.2.4 View the power station</a> for detail.

## 1.6 Naming rules

- Naming rules for main battery pack

**ATZ 3600 EU**

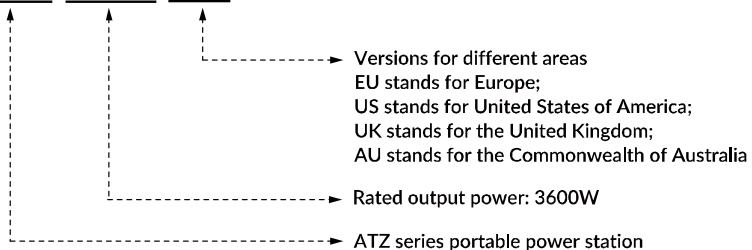

- Naming rules for secondary battery pack



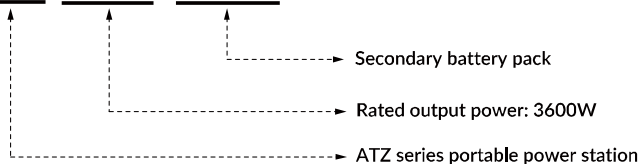



**ATZ 3600 BATT**

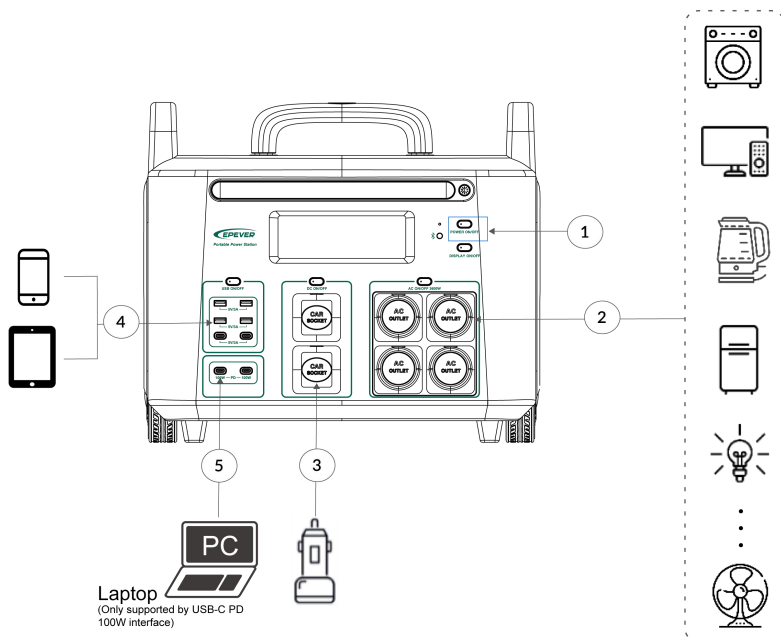







## 2 Use the Power Station

### 2.1 Outward power supply



1	Press and hold  button for 3 seconds to power on the power station.
2	AC output: Press  button to power on the AC output, the AC load icon  lights up after about 5 seconds. Press the switch again to power off the AC output, the AC load icon  goes out after about 5 seconds.
3	DC output: Press  button to power on the DC output, the cigarette lighter icon  lights up. Press the switch again to power off the DC output, the cigarette lighter icon  goes out within 1 second to 2 seconds.

4	<p>USB-A and USB-C output: Press  button to power on the output of USB-A and USB-C ports, the USB-A icon  lights up. Press the switch again to power off the output of USB-A and USB-C ports, the USB-A icon  goes out.</p>
5	<p>USB-C PD output: When the USB-C PD port is connected to a device, the output of USB-C PD port will be powered on automatically, and the USB-C PD icon  lights up. Disconnect the device to power off the output of USB-C PD port , the USB-C PD icon  goes out.</p>



When the DC or AC output power is higher than the minimum measurable value, the "OUTPUT" icon and output power  will be displayed on the right side of the LCD.

## 2.2 Charge the power station

This power station supports four charging modes: solar charging, car charging (charging via the car cigarette lighter socket), AC charging, solar plus AC simultaneous charging.

- The power station will be activated directly for charging when the AC or DC power is connected.
- This power station supports DC-only charging, AC-only charging, or DC and AC charging simultaneous.
- When there is charging power, the LCD shows INPUT and charging power .
- During the charging process, the SOC battery bar on the LCD flashes to display the battery capacity in real time.

### 2.2.1 Grounding

 <b>NO GROUNDING</b>	<ul style="list-style-type: none"> <li><input checked="" type="checkbox"/> Do not connect the battery terminals to ground.</li> <li><input checked="" type="checkbox"/> Do not connect the PV terminals to ground.</li> <li><input checked="" type="checkbox"/> Do not connect the AC input terminals L and N between the power station and the household distribution cabinet to ground.</li> <li><input checked="" type="checkbox"/> Do not connect the AC output terminals L and N to ground.</li> </ul>
 <b>GROUNDING</b>	<ul style="list-style-type: none"> <li><input checked="" type="checkbox"/> The grounding terminals of AC input and output must be properly connected to ground.</li> </ul>

## 2.2.2 Solar power charging

Connect the solar panel to the SOLAR/CAR INPUT port of the power station using the PV charging cable provided in the package to initiate charging. You may use one or multiple solar panels. If multiple panels are to be connected, they must be connected in series or in parallel first before being connected to the power station. With a 1,200W input, it takes 1.7 hours to fully charge the power station. In actual charging operations, the charging time may vary depending on various factors such as weather conditions, sunlight intensity, and panel orientation.

- The input voltage range of the solar panel is 11VDC to 60VDC, and the maximum charging power is 1,200W.
- When using the solar panel to charge the power station, please read the detailed operating instructions of the solar connector before use.
- The connector for solar series or parallel connection is not included, and is purchased separately. Please read the detailed operating instructions of the solar connector before use.



**WARNING**

Ensure terminal polarities correctly during connection, and do not connect them in reverse.

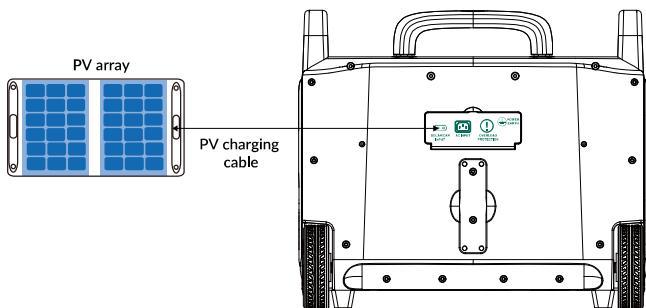

**Solar charging time:** (1,200W input power) It takes 1.7 hours to fully charge the main battery pack.

## 2.2.3 Car charging

It is prohibited to simultaneously use both the solar charging and car charging; only one of the ways can be used. Connect the SOLAR/CAR INPUT port of the power station to the car cigarette lighter socket via the supplied car charging cable to charge the power station.

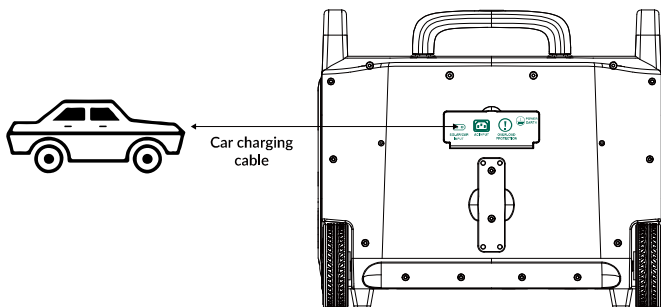

**Car cigarette lighter socket charging time:** It takes 17 hours to fully charge the main battery pack.

### 2.2.4 AC charging

Please use the supplied AC charging cable to connect the AC INPUT port of the power station and the AC socket in the wall for charging.

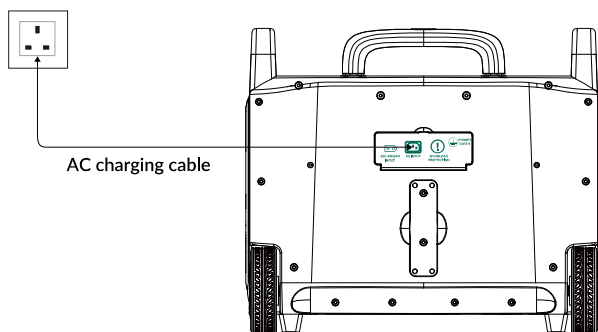

**AC charging time:** It takes 1.2 hours to fully charge the main battery pack of model ATZ3600EU/UK/AU, and 1.6 hours for ATZ3600US.

### 2.2.5 Solar plus AC simultaneous charging

When AC charging and solar charging are enabled at the same time, the product will give priority to solar charging and use the two methods at the same time to charge the battery at the maximum allowable power.

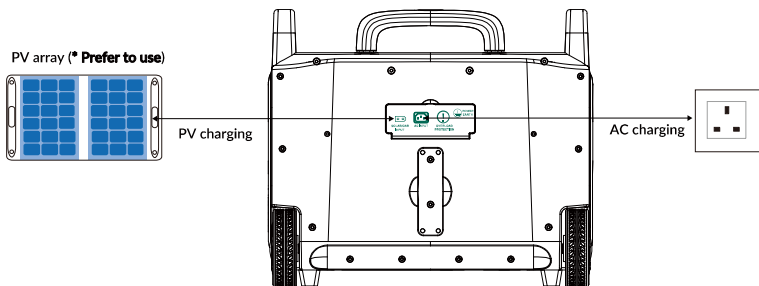

**AC charging plus the maximum PV charging time:** It can only charge the main battery pack at the same time, and it takes 1.2 hours to fully charge.

### 2.3 EPS (Emergency Power Supply)

This power station supports EPS to serve as an emergency indoor power supply, delivering dependable electricity when needed. When connect the AC charging cable to the charging AC input port of the device, the electrical device can be powered via the AC output port(AC power will come form the grid and not the power station at this situation). In case of a sudden power failure, the power station can automatically switch to the battery powered supply within 30ms.



**WARNING**

This function does not support 0ms switching. Please do not connect the power station to any device that requires 0ms UPS, such as data servers and medical equipment. EPERVER takes no responsibilities for any device malfunctions caused by failures to follow instructions.

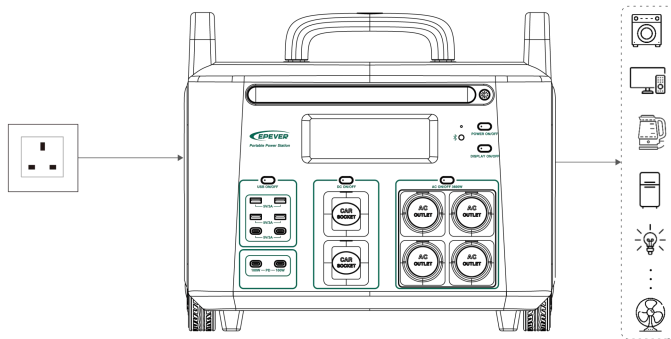



## 2.4 Connect to secondary battery pack (Optional)

### 2.4.1 Appearance of secondary battery pack

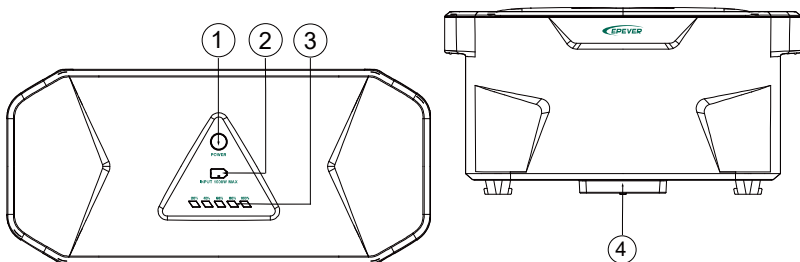

1	Power button <sup>①</sup>	3	Capacity indicator
2	Solar panel/Car cigarette lighter socket charging terminal	4	Connection terminal (connected to main battery pack)

(1) Operation instructions for the power button of the secondary battery pack:

**Press for 1 second:** The capacity indicator is solid on, and the secondary battery pack is powered on.

**Press for 3 seconds:** The tail light of the capacity indicator flashes, indicating that the secondary battery pack turns on the charging and discharging power.

**Press for 5 seconds:** Turns off the charging and discharging power, and later shuts down the secondary battery pack (the secondary battery pack is not connected to the main battery pack).

### 2.4.2 Installation of secondary battery pack

**Step 1:** Remove the fixing screws of the cover plate on the top, and move the cover plates left and right to expose the connecting terminals.

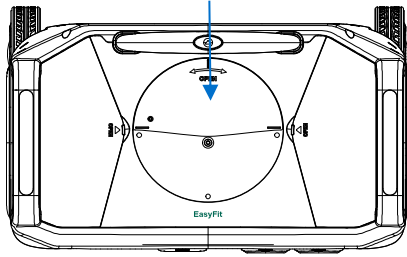

**Step 2:** Remove the cover plates on the left and right sides of the portable power station.

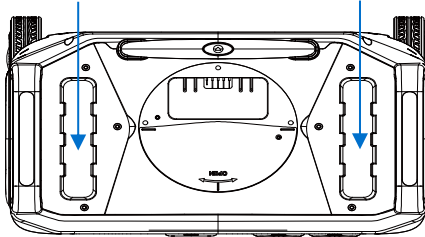

**Step 3:** Put the secondary battery pack into the slots on both sides of the portable power station and push it backward to clamp it tightly.

**Note:** The protective cover on the connection terminal of the secondary battery pack must be removed before connecting.

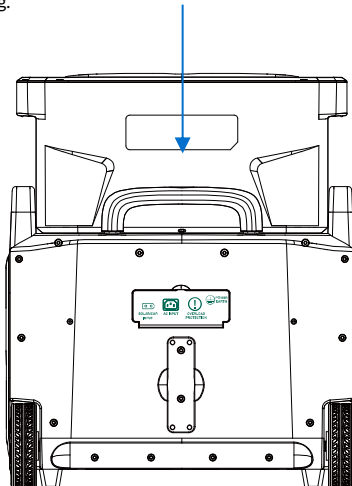



After installing the secondary battery pack, the portable power station must not be moved or swing significantly. Otherwise, there is a risk of the secondary battery pack falling!

## 2.5 Application scenarios

- Charging the main battery pack

No.	Applicable scenarios	Instructions
1	When the secondary battery pack is connected to the main battery pack, and it needs to charge the main battery pack.	<ul style="list-style-type: none"><li>• Power on the main battery pack first, within 10 seconds, press the power button of the secondary battery pack for 3 seconds to charging the main battery pack;</li><li>• Or press the power button of the secondary battery pack for 3 seconds to turn on the discharging, and then power on the main battery pack; the secondary battery pack will charging the main battery pack.</li></ul> <p><b>Note:</b> The secondary battery pack will not turn on the charging and discharging automatically, you must manually press the power button of the secondary battery pack for 3 seconds to turn on the charging and discharging.</p> <p>If the PV panels or AC power is connected to the main battery pack before the secondary battery pack was connected, the secondary battery pack will not charge the main battery pack.</p>
2	When the main battery pack supplies power to the load, the secondary battery pack must supply power at the same time.	Press the power button of the secondary battery pack for 3 seconds to turn on the discharging.
3	After the secondary battery pack is connected to the main battery pack, the AC and PV panels are simultaneously connected to the main battery pack.	The AC and PV panels are preferred to charging the main battery pack until the main battery pack is fully charged. If you need to charge the secondary battery pack, disconnect the PV panel first.

4	In the process of secondary battery pack charging the main battery pack.	<ul style="list-style-type: none"> <li>Do not set the charging mode as “Standard (mute charge)” in the APP. Setting to the standard charge mode is an invalid operation.</li> <li>Do not power off the main battery pack directly or power it off by the remote controller/APP. Please turn off the secondary battery pack by pressing the power button for 5 seconds, and then power off the main battery pack.</li> </ul>
5	In the process of charging the main battery pack, the AC power or PV panel is connected to the main battery pack.	<p>The secondary battery pack stops charging the main battery pack, and the AC power or PV panel is preferred to charging the main battery pack.</p> <p><b>Note:</b> The AC power and PV panel can charge the main battery pack at the same time. If you want to power off the main battery pack during charging, you need to disconnect the AC or PV panels.</p>

- Charging the secondary battery pack

No.	Applicable scenarios	Instructions
1	The secondary battery pack is not connected to the main battery pack.	The secondary battery pack can be connected to PV panels for charging independently.
2	After the secondary battery pack is connected to the main battery pack, there is only one set of PV panel.	<p>It is recommended that this set of the PV panels be connected to the main battery pack for charging first. When the main battery pack is fully charged, the PV panel will not charge the secondary battery pack. If you need to charge the secondary battery pack, disconnect the PV panel from the main battery pack, and turn off the main battery pack. And then connect the PV panel to the secondary battery pack for charging independently.</p> <p><b>Note:</b> The main battery pack cannot be powered on when charging the secondary battery pack, otherwise, the charging process of the secondary battery pack will be stopped.</p>
3	After the secondary battery pack is connected to the main battery pack, there are two sets of PV panel.	Disconnect the secondary battery pack from the main battery pack, and separately connect each to a PV panel for charging.

4	After the secondary battery pack is connected to the main battery pack, there is AC connected.	<p>The AC power is preferred for charging the main battery pack. Once the main battery pack is fully charged, the AC power will automatically charging the secondary battery pack.</p> <p><b>Note:</b> During the charging process of the secondary battery pack, do not connect the PV panels, as this will interrupt the charging.</p>
---	--	--

## 2.6 Protections for the secondary battery pack

No.	Applicable scenarios	Instructions
1	During the charging and discharging process of the secondary battery pack, the temperature of DC/DC module on the main board is too high.	At this time, the secondary battery pack is activated by over-temperature protection and automatic turn off the charging and discharging. After the temperature drops, the charging and discharging will recover automatic.
2	During the charging process from the secondary battery pack to the main battery pack, the AC output power is too high and loads are turned on/off frequently.	At this time, the secondary battery pack is prone to over-power protection. Press the power button of the secondary battery pack for 5 seconds to power off the discharging. In the event that the secondary battery pack's power button fails to reset after an over-power protection occurs, the secondary battery pack will automatically resume discharging after approximately 10 minutes.
3	During the charging process from the secondary battery pack to the main battery pack, the secondary battery pack may trigger a high temperature or low temperature protection.	The secondary battery pack will automatically turn off the discharging. After the temperature of the secondary battery pack decreases or rises, manually press the power button of the secondary battery pack for 3 seconds to turn on the discharging, and then recharge the main battery pack.
4	During the process of AC charging the secondary battery pack, the secondary battery pack is protected by high temperature or low temperature.	At this time, even if the temperature decreases or increases, the secondary battery pack will not automatically resume charging. It needs to first disconnect the AC power, and turn off the main battery pack. Subsequently, upon re-establishing the AC connection, the main and secondary battery packs will be automatically activated, allowing for the recharging to the secondary battery pack.

### 3 Remote Control of Power Station

#### 3.1 Remote controller

ATZ3600 power station is equipped with a remote controller.

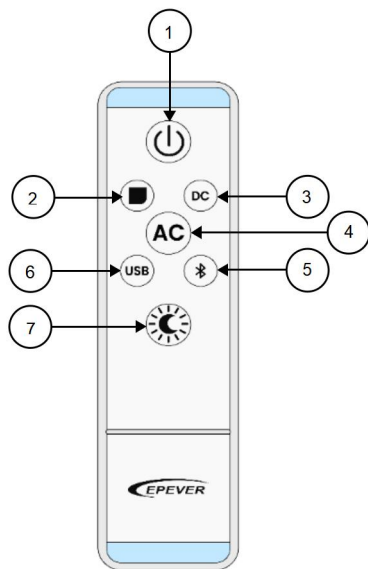

The remote controller's buttons are introduced as follows:

1	Power button	Press the button to power off (the remote controller can be only used for powering off, and not for powering on; the device can be powered on through the power switch of the device).
2	LCD display button	Press the button to power on LCD screen, and press it again to power off the LCD screen.

3	DC output switch	Press the button to turn on the cigarette lighter output, and press it again to clear the fault (if exists) or turn off the DC output.
4	AC output switch	Press the button to turn on the AC output, and press it again to turn off the AC output.
5	Bluetooth communication switch	Press the button to turn on the Bluetooth communication, and press it again to turn off the Bluetooth communication.
6	USB switch	Press the button to turn on the USB-A and USB-C output, and press it again to clear the fault (if exists) or turn off the USB-A and USB-C output.
7	Ambient light switch	The first click turns on level 3 brightness, the second click turns on level 2 brightness, the third click turns on level 1 brightness, and the fourth click turns off the ambient light. Long press the switch for 3 seconds to enter the SOS mode.

#### Remote Controller specification:

Parameter Name	Value	Parameter Name	Value
Working voltage	12VDC	Modulation method	Amplitude modulation
Working current	≤ 15mA	Encoding chip	Fixed code
Working frequency	433.92MHz	Battery	23A/12VDC
Transmission power	-40.35dBm	Number of buttons	7 keys

Launch distance	3 - 10 meters (Open environment )	Shell material	ABS plus iron sheet plus silicone
Transmission rate	1 - 5KHZ	Product size	120mm × 31mm × 13.5mm
Frequency deviation	±0.2MHz		4.7 × 1.2 × 0.5 inches

### 3.2 APP remote control

You can view the power station information, update the software version, monitor the working status and personalize the settings through the APP.

#### 3.2.1 Download the APP

Use the default browser of the mobile phone to scan the following QR code to download the APP installation package, and successfully install it on the mobile phone.



**Note:** For iPhone users, please search for "EcoMova" in the App Store to download.



### 3.2.2 Register and Log in the APP

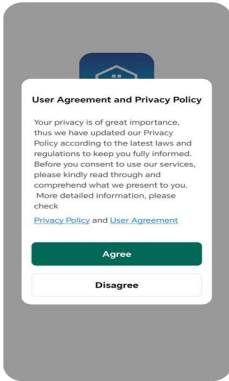

1. After the APP is downloaded and installed, open the APP and click "Agree" to agree the "User Agreement and Privacy Policy."

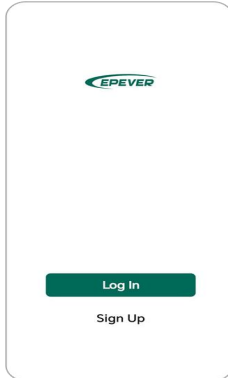

2. For the first time, click "Sign Up" to enter the registration screen. If you already have an account, click "Log In."

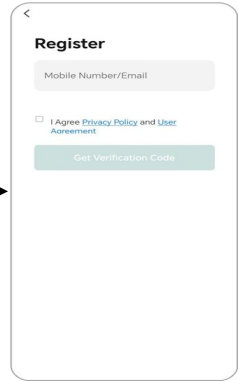

3. On the "Register" screen, enter your mobile phone number or email address, and click "Get Verification Code."

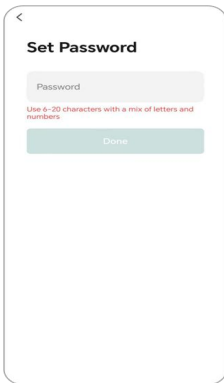

4. Enter the received verification code to enter the password setting screen, set the password of the new account, and click "Done."



5. After the account registration is successful, click "Go to App."

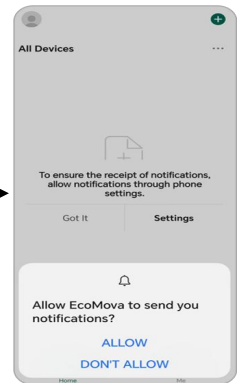

6. In the next screens, set whether to allow the APP to send notifications, enable the notification permission and location permission.



## IMPORTANT

Location permissions must be enabled during the APP running process. If the location is disabled, the devices cannot be added into the APP.

If the location permission is not enabled during account registration, you can perform the following operations to enable it.

**Method 1:** Click "Settings > Apps > Apps" on the mobile phone, find the "EcoMova" APP, and enable the location permission according to the following flow chart.

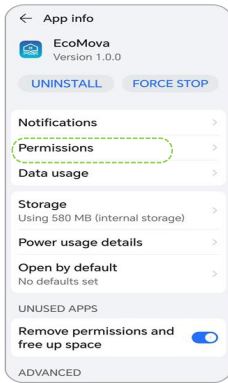

1. Click "Permissions".

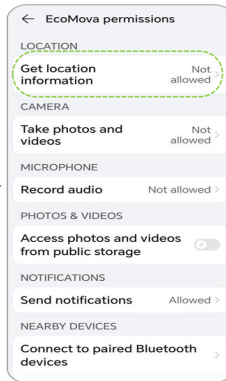

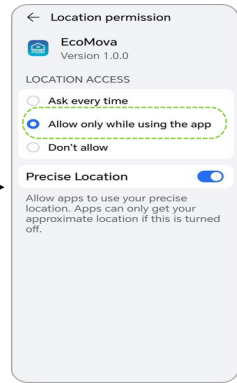

2. Click "Get location information."

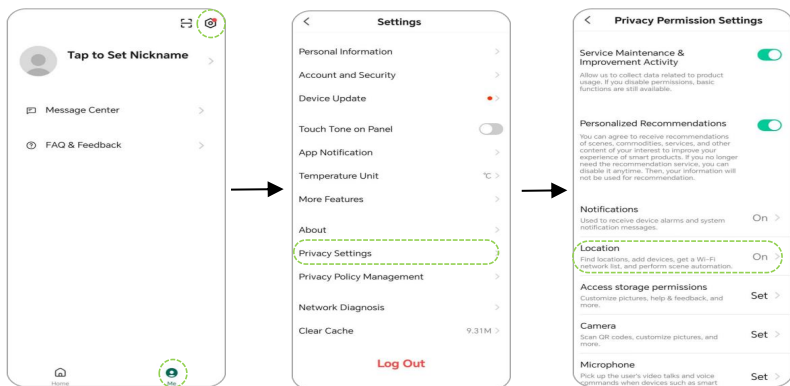

3. Set location permission to "Allow only while using the app."

**Method 2:** In the "Me" screen of the "EcoMova" APP, click  in the upper right corner to enter the "Settings" screen. And click "Privacy Settings > Location" to enter the "App info" screen. Enable the location permission of the APP.





**Note:** The red dot on the icon  indicates that a newer software version is available.

### 3.2.3 Add the power station



#### IMPORTANT

Before adding the power station, you must click the Bluetooth switch  to enable the Bluetooth function, turn on the Bluetooth and location information of the mobile phone, and enable the location permission of the APP. Otherwise, the power station cannot be added successfully.

If you are unable to detect nearby power stations for an extended period, it is possible that this power station has been added or bound by another account. When the Bluetooth switch  is turned on, press and hold  to release the binding between this power station and other accounts.

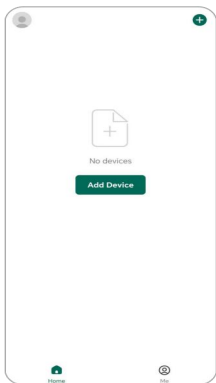

1. On the home page, click "Add Device" or  in the upper right corner.

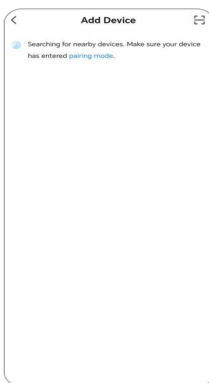

2. Enter the "Add Device" screen, the available power stations nearby is searched automatically.

Note: It is a must to turn on the Bluetooth function and location permission. Otherwise the power station cannot be searched.

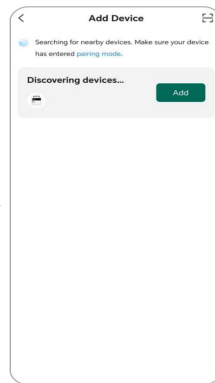

3. Click "Add" to start the adding process of the power station.



4. Adding the power station

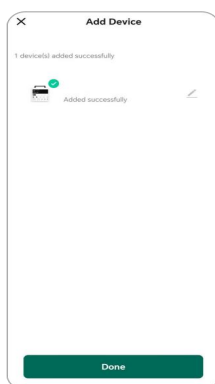

5. Click "Done" to finish.



6. Enter the home screen of the power station for viewing information and setting related functions.

### 3.2.4 View the power station

After the power station is successfully connected, enter the following APP home page.

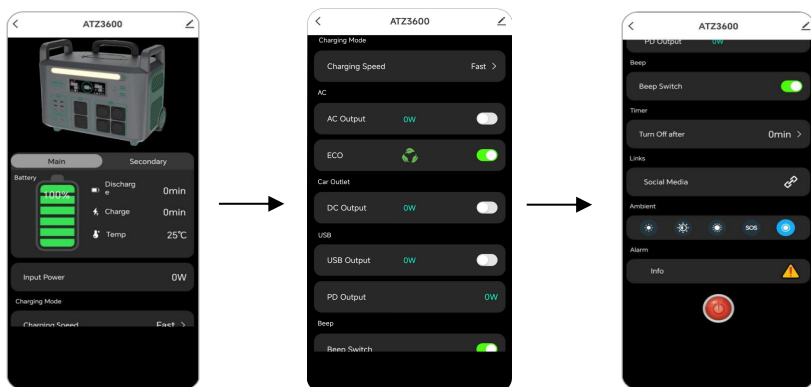



Parameter	Parameter specification
Main battery pack/secondary battery pack	Click "Main" and "Secondary" to view relevant information of the main battery pack and secondary battery pack. <b>Note:</b> Only when the secondary battery pack is connected, click "Secondary" will display the information about the secondary battery pack.
Battery	Main battery information or secondary battery pack information, including discharge remaining time, charge remaining time, and battery temperature.
Input power	Display the sum of DC input and AC input power.
Charging mode	Valid only in mains power charging. Standard: Mute charging. The power is about 600W. Fan usually does not start for a long period, keeping it noise-free. Fast: Normal charging. Maximum power of 2,000W for ATZ3600EU/UK/AU, and maximum 1,400W for ATZ3600US.
AC output	Turn on or off the AC output. The AC output power will display after turning on the button.

Parameter	Parameter specification
ECO	<p>Enable/Disable the ECO mode (ECO is enabled by default after the power station is powered on).</p> <p><b>Enabled:</b> The power station will automatically power off when the AC output power is less than 50W (ATZ3600EU/ATZ3600UK/ATZ3600AU) / 30W (ATZ3600US) and lasts for 8 hours; when there is no input and output on the power station for 30 minutes, it will automatically shut down.</p> <p><b>Disabled:</b> The power station will not shut down automatically once its AC output is turned on.</p>
DC output	Turn on or off the cigarette lighter output. The DC output power will display after turning on the button.
USB output	Turn on or off the USB output. The USB output power will display after turning on the button. The PD output power will display automatically when the PD port is connected to a device.
Beep switch	Turn on or off the beep. After turning it on, a buzzing remind will be heard when operating the power station.
Timer	<p>Set the device shutdown time, the set range is 1 to 255 minutes. Upon expiration of the set time, the power station will automatically shutdown. When there is AC and DC input, or the secondary battery pack charging the main battery pack, the timing is invalid. When set to 0, cancel the timing.</p> <p><b>Note:</b> Remote shutdown via the APP is possible, but remote startup is not supported. To power on the power station, the physical power switch must be used.</p>
Web links	Click to select the web links (currently support Facebook and Twitter), and automatically jump to the corresponding site.
Ambient light	It is the brightness of level 1, level 2, level 3, the SOS mode, and close the ambient light from left to right.
Alarm	<p>Click to display all abnormal information that occurred during the connection between the power station and the APP.</p> <p><b>Note:</b> The abnormal information that occurs when the power station is not connected to the APP will not be saved by the APP.</p>
Power off	Click this button to power off the power station. After the power station is powered off, it must be manually powered on via the power switch.

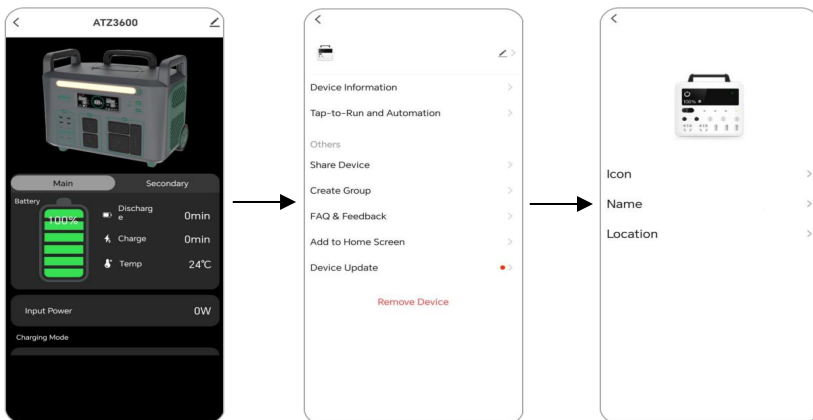
### 3.2.5 Edit the power station



1. On the power station screen, click the icon  in the upper right corner.

2. Enter the device editing screen and click the icon  after the device name.

3. Modify the device icon, name, and location information.

**Note:** On the device editing screen, you can also update the device or remove the device etc.

### 3.2.6 Software update



#### WARNING

Before updating the device, please disconnect the main battery pack and the secondary battery pack, otherwise the device may be powered off after the failure of updating.

When the battery capacity drops to or below 5%, the system prohibits software upgrades. And the upgrade failure will be prompted after click "Update" on the APP.

Click the edit icon  in the upper right corner > click "Device Update"> click "Update" to perform firmware update after entering the APP home page.



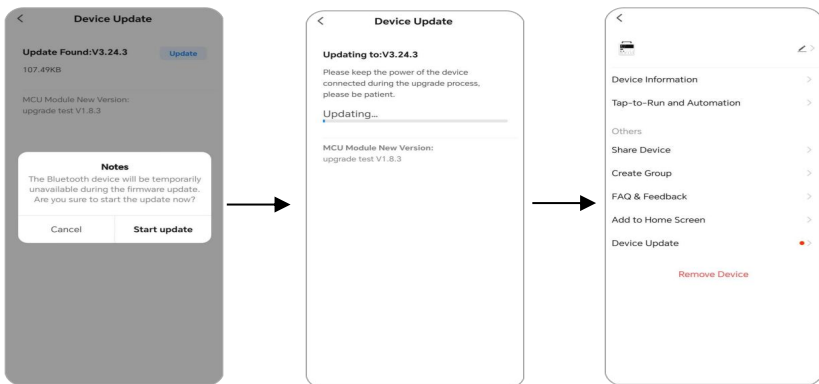

Click "Start update" to upgrade the software. Upon completion, the system will automatically return to the device editing screen, displaying "Latest version."



During the process of software upgrading, the LCD displays 2000, which indicates the update of the OTA.

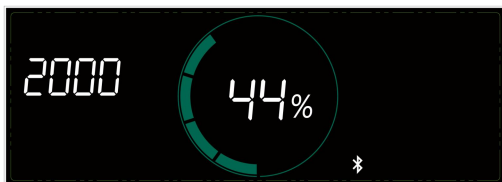



After the software download is completed, the LCD screen of the power station will turn off, accompanied by the blinking of the indicator on the  switch. Approximately 30 seconds later, the LCD screen will light up again, indicating the software upgrade is completed.



### IMPORTANT

During software upgrading, make sure the Bluetooth connection is stable. Keep the mobile phone in close proximity to the device and remain on the current upgrade interface at all times. Do not switch the APP to run in the background. Meanwhile, ensure that the mobile phone has a good network signal. Otherwise, the upgrade may fail.

If the upgrade fails, the Bluetooth connection between the power station and the APP will be disconnected. You need to return to the APP home page to reconnect the power station and continue to upgrade.

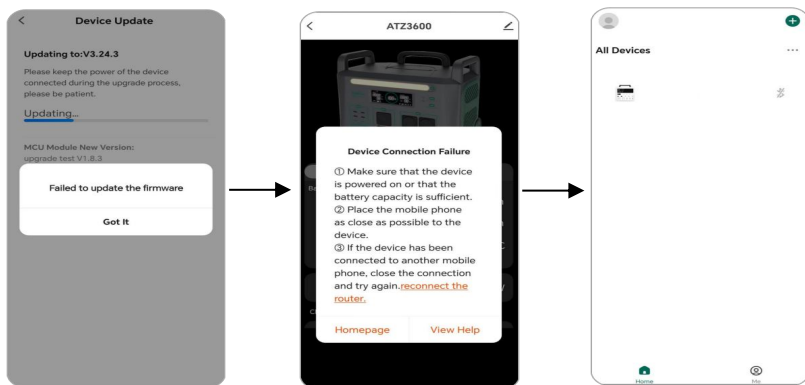

1. Click the "Got it" to exit the current screen. **Note:** To ensure the success of the upgrade, please do not directly click "Update" on this interface.

2. Return to the APP home page, a "Device Connection Failure" prompt message appears. Click "Homepage."

3. Enter the device reconnecting screen, and click the Bluetooth icon, the device and APP automatically reconnect.

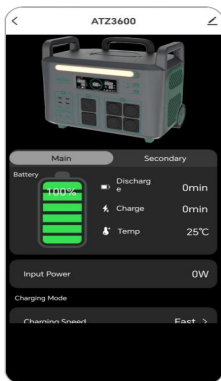

4. After the device is successfully reconnected, return to APP home page automatically. Click the icon  in the upper right corner.

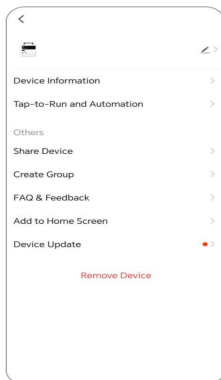



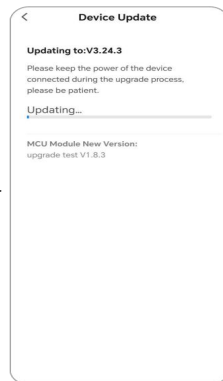



5. Re-enter the device editing screen and click "Device Update" again.



6. Automatically continue the last updated until it updating successfully.

## 4 Troubleshooting

No.	Faults	Abnormalities	Solution
1	DC Input Overvoltage	<p>The power station stops charging.</p> <p>The failure content is reported to APP.</p> <p>You can click "Alarm &gt; Info" on the APP to view the specific fault content.</p>	Unplug the DC input plug, and measure whether the DC input voltage exceeds 62VDC.
2	DC Input Undervoltage		Unplug the DC input plug, and measure whether the DC input voltage is lower than 10VDC.
3	AC Input Overvoltage		Unplug the AC input plug, and measure whether the AC input voltage exceeds 263VAC (ATZ3600EU/UK/AU) or 140VAC (ATZ3600US).
4	AC Input Undervoltage		Unplug the AC input plug, and measure whether the AC input voltage is lower than 176VAC (ATZ3600EU/UK/AU) or 100VAC (ATZ3600US).
5	USB Overload	<p>The corresponding output port stops discharging.</p> <p>The failure content is reported to APP.</p> <p>You can click "Alarm &gt; Info" on the APP to view the specific fault content.</p>	<p>Remove the abnormal load, and press the button  to restore output.</p> <p><b>Note:</b> Each USB port is powered individually, and USB overload will only shut down the output of the respective port.</p>
6	Cigarette Lighter Socket Overload		Remove the abnormal load, and press the button  to restore output.
7	Cigarette Lighter Output Short Circuit		Disconnect the short-circuit device, and press the button  to restore output.
8	PD Overload		Remove the abnormal device, re-plug the device and restore output.

9	AC Output Overload	<p>The AC output is turned off after the fault occurs, and the corresponding icon on the LCD disappears.</p> <p>The failure content is reported to APP.</p> <p>You can click "Alarm &gt; Info" on the APP to view the specific fault content.</p>	<p>Remove the overpower device, and reduce devices used in the output ports. Electrical appliances must be used within the rated power. When there is AC input, the output load is limited to be lower than 2,000W (ATZ3600EU/UK/AU) or 1,400W (ATZ3600US).</p>
10	AC Output Overload Lockout	<p>The AC output is turned off after the fault occurs, and the corresponding icon on the LCD disappears.</p> <p>The failure content is reported to APP.</p> <p>You can click "Alarm &gt; Info" on the APP to view the specific fault content.</p>	<p>Restart the power station and press the button  to restore output.</p>
11	Main Battery High Temperature	<p>LCD displays the high temperature alarm icon .</p>	<p>Wait for the main battery pack to cool down, and resume charging only after the LCD warning indication disappeared</p>
12	Secondary Battery High Temperature	<p>With 3 warning alerts, charging will be stopped.</p>	<p>Wait for the secondary battery pack to cool down. After the LCD warning indication disappears, manually press the power button of the secondary battery pack for 3 seconds to resume the charging and discharging.</p>
13	Main Battery Low Temperature	<p>LCD displays the low temperature alarm icon .</p>	<p>Wait for the main battery pack to heat up, and resume charging only after the LCD warning indication disappeared</p>
14	Secondary Battery Low Temperature	<p>With 3 warning alerts, charging will be stopped.</p>	<p>Wait for the secondary battery pack to cool down. After the LCD warning indication disappears, manually press the power button of the secondary battery pack for 3 seconds to resume the charging and discharging.</p>

15	Inverter Module High Temperature	<p>The power station stops charging and discharging.</p> <p>The failure content is reported to APP.</p> <p>You can click "Alarm &gt; Info" on the APP to view the specific fault content.</p>	Stop the charging and discharging, and then using after cooling.
16	Internal Ambient High Temperature		Stop the charging and discharging, and then using after cooling.
17	PV High Temperature		Check whether the air duct and fan are abnormal.
18	Grid Frequency Abnormal		<p>In this case, the Bypass mode is forbidden.</p> <p><b><u>Bypass:</u></b> While the AC charging is in progress, the AC output is activated, but the battery does not power the AC output.</p> <p>If overload occurs in the bypass mode, the AC output will be turned off. Restart the power station to resume the AC output. The high instantaneous AC output power in the bypass mode may damage the power station.</p>

## 5 Technical Specifications

### 5.1 Parameters for main battery pack

Product Model		ATZ3600EU	ATZ3600UK	ATZ3600AU	ATZ3600US
AC Input	Rated AC Input Voltage	230VAC		240VAC	120VAC
	AC Voltage Range	200 - 240VAC			100-140VAC
	Breakdown Voltage	290VAC			200VAC
	AC Input Frequency	50Hz/60Hz			60HZ/50HZ
	Rated AC Input Power	2,300W			1,400W
	Overload Protection Relay	HAVE			
DC Input	Maximum withstand Voltage at PV Input Terminal	60VDC			
	PV Controller Type	MPPT			
	MPPT Maximum Efficiency	≥ 99.5%			
	MPPT Voltage Range	11VDC-60VDC			
	MPPT Number	1			
	Maximum PV Charging Current	20A (when the PV input voltage is less than 30VDC, the maximum PV charging current is 10A)			
	Maximum DC Input Power	1,200W			
Car Charging	12VDC/10A				
AC Output	Rated Output Power (@25℃)	3,600W			
	Rated Output Power of Bypass (@25℃)	2,300W			1,400W

	3-second Transient Surge Output Power	5,400W	
	Output Voltage Level	230VAC $\pm$ 3%	
	Output Frequency Level	50 Hz (error $\pm$ 0.2%)	60 Hz (error $\pm$ 0.2%)
	Output Voltage Waveform	Pure sine wave	
	Output Voltage Harmonic Distortion	$\leq$ 3% (pure resistive load)	
DC Output	USB-A Output	5VDC/3A*2 (four USB-A ports (sharing a 5VDC/3A for every two ports))	
	USB-C Output	5VDC/3A (two USB-C ports (sharing a 5VDC/3A power supply))	
	USB-C PD Output	PD 100W * 2 (The protocol supports PD2.0, PD3.0, QC2.0, QC3.0, QC4+ and APPLE 5V/2.4A)	
	Cigarette Lighter Output	12VDC/10A*2	
Battery	Battery Type	Lithium iron phosphate	
	Rated Voltage	51.2VDC	
	Range of Operating Voltage	40.0VDC-58.4VDC	
	Range of Operating Temperature	Discharging: -20°C to 50°C; Charging: 0°C to 50°C	
	Nominal Capacity	2,048Wh	
Charging Time	AC Charging	1.2 hours	1.6 hours
	Car Charging	17 hours	
	Solar Charging (1200W input power)	1.7 hours	
	AC Charging Plus Maximum PV Charging	1.2 hours	

Others	Charging Environment Temperature	0°C to 40°C (±3°C)
	Discharging Environment Temperature	-20°C to 40°C (±3°C) (derating is required for use at greater than 35°C)
	Recommended Working Environment Temperature	20°C to 35°C
	Storage Environment Temperature	1 month: -10°C to 50°C; 3 months: -10°C to 45°C; 6 months: -10°C to 30°C (High-temperature storage is not recommended; the storage time shall not exceed half a year, and it must be charged once every six months.)
	Relative Humidity	< 80%
	Altitude	< 4,000 meters (derating is required for operation at greater than 2,000m)
	Protection Degree	IP20
	Communication Mode	Bluetooth
	Man-machine Interface	Monochrome LCD, English interface
	Dimension (Length × Width × Height)	Without secondary battery pack: 456mm × 290mm × 391mm (18in × 11.4in × 15.4in) With secondary battery pack: 456mm × 290mm × 537mm (18in × 11.4in × 21.1in)
Net Weight	Without secondary battery pack: 29.0kg (63.9 pounds) With secondary battery pack: 44.5kg (98.1 pounds)	



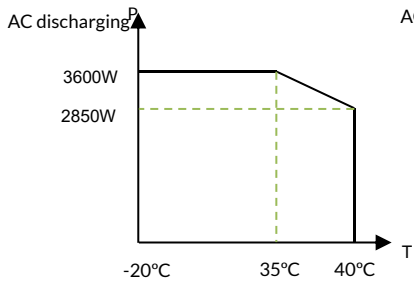

AC discharging power Vs temperature

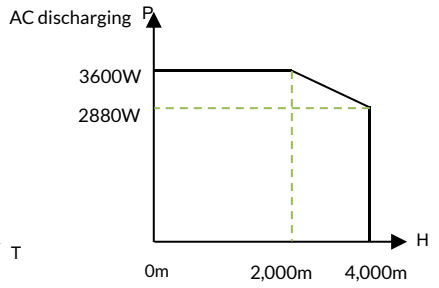

AC discharging power Vs altitude

## 5.2 Parameters for secondary battery pack

Product Model		ATZ3600-BATT
Battery	Battery Type	Lithium iron phosphate
	Rated Voltage	51.2VDC
	Range of Operating Voltage	40.0VDC to 58.4VDC
	Range of Operating Temperature	Discharging: -20°C to 50°C; Charging: 0°C to 50°C
	Nominal Capacity	2048Wh
Discharging	Rated Discharging Power	1000W
Charging	AC Charging Time	2.1 hours
	AC Charging Power	1000W
	Maximum MPPT Input Power	1000W
	MPPT Voltage Range	11VDC-60VDC
	Maximum PV Charging Current	20A (when the PV input voltage is less than 30VDC, the maximum PV charging current is 10A)
	Solar Charging Time (1000W input power)	2.1 hours
Others	Charging Environment Temperature	0°C to 40°C ( $\pm 3^{\circ}\text{C}$ )
	Discharging Environment Temperature	-20°C to 40°C ( $\pm 3^{\circ}\text{C}$ )
	Recommended Working Environment Temperature	20°C to 35°C
	Storage Environment Temperature	1 month: -10°C to 50°C; 3 months: -10°C to 45°C; 6 months: -10°C to 30°C (high-temperature storage is not recommended; the storage time shall not exceed half a year, and it must be charged once every six months.)

Relative Humidity	< 80%
Altitude	< 4,000 meters
Protection Degree	IP20
Dimension (Length × Width × Height)	428mm × 196mm × 224.4mm (16.9in × 7.7in × 8.8in)
Net Weight	15.5kg (34.2lb)



**+86 - 752-3889706**

**info@epever.com**

**www.epever.com**

**HUIZHOU EPEVER TECHNOLOGY CO., LTD.**

**Any changes without prior notice! Version number: V1.1**